



BlackGEM Telescope array



BlackGEM-3 installed at La Silla

- Gravitational wave counterparts
- Six-band Southern All Sky Survey
- Three-band Synoptic Survey
- Nearby Universe monitoring program

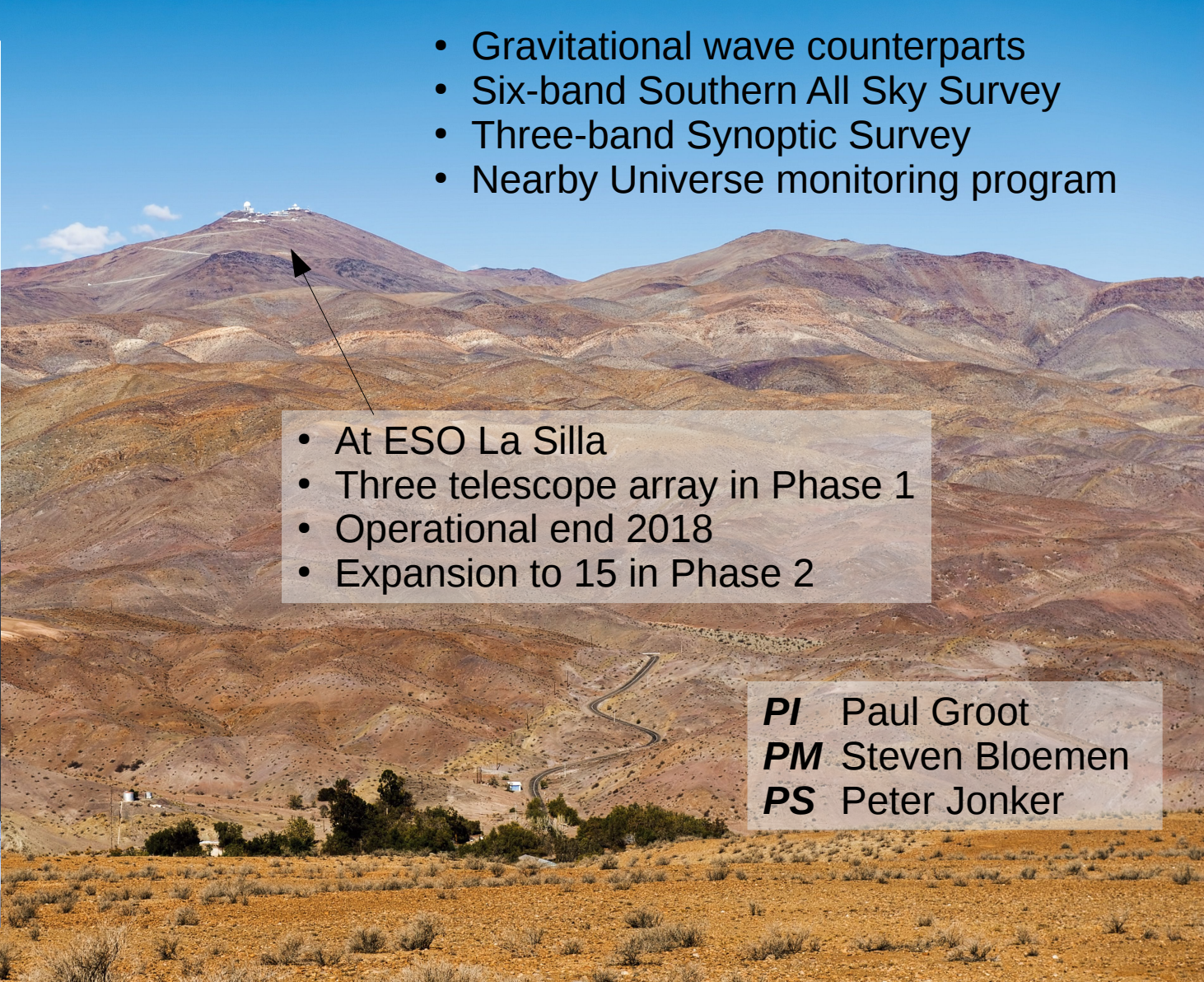
- 
- At ESO La Silla
 - Three telescope array in Phase 1
 - Operational end 2018
 - Expansion to 15 in Phase 2

PI Paul Groot
PM Steven Bloemen
PS Peter Jonker



BlackGEM Team & Consortium

Principal Investigator: Paul Groot (Radboud University)
Project Scientist: Peter Jonker (SRON/Radboud University)
Project Manager: Steven Bloemen (Radboud University)

Consortium Institute Partners in Phase 1:



NOVA = Amsterdam, Leiden, Groningen, Radboud

Radboud Universiteit



KU Leuven

Manchester U., Tel Aviv U., UC Davis, Weizmann, Hebrew U, Potsdam, TexasTech, DTU and UCD have entered at PI level.

Possibility for new partners (for 5 year operation):

- 150 kEuro to join at PI-level (one faculty member + PDRAs/PhDs)
(all data, science team, lead science case)
- 1 - 1.5 MEuro (negotiable) to join at Institute level (full institute)
(all data, science team, lead science case, consortium board)

→ Combinations with in-kind contributions (e.g. follow-up telescope time) possible

www.blackgem.org ; @BlackGEM_Array



BlackGEM

Science:

- **Gravitational wave counterparts**
- Southern All Sky Survey
- Fast Transients & Variables
- Nearby Universe Survey

Phase 1:

- 3 wide field telescopes (8.1 square degr. total)
- Primary mirror: 65cm diameter
- Sensitivity: $g=23$ in 5 minutes
- Location: ESO La Silla
- Optical quality: seeing limited, 0.9" median
- Camera: 1 CCD/telescope, 10k x 10k, 0.56"/pixel
- Filters: u, g, q, r, i, z filter set, change in 3s

Phase 2:

- Expansion to 15 telescopes
- 40 square degrees total field of view (@ 0.56"/pix)
- Location: ESO La Silla; or combi ESO, NZ and SA





BlackGEM Unit telescope

- Wynne-Harmer design incl. M2 on tip-tilt piezo stage
- 110 Mpix camera (1 STA 1600 chip)
- 2.7 square degree field-of-view @ 0.56"/pix
- 10 second readout + filter change + repointing
- Carbon-fibre structure
- Atmospheric Dispersion Corrector in triplet lens barrel
- Fornax 200 mount
- Fully robotic
- Cooled electronics, in counterweight



MeerLICHT prototype

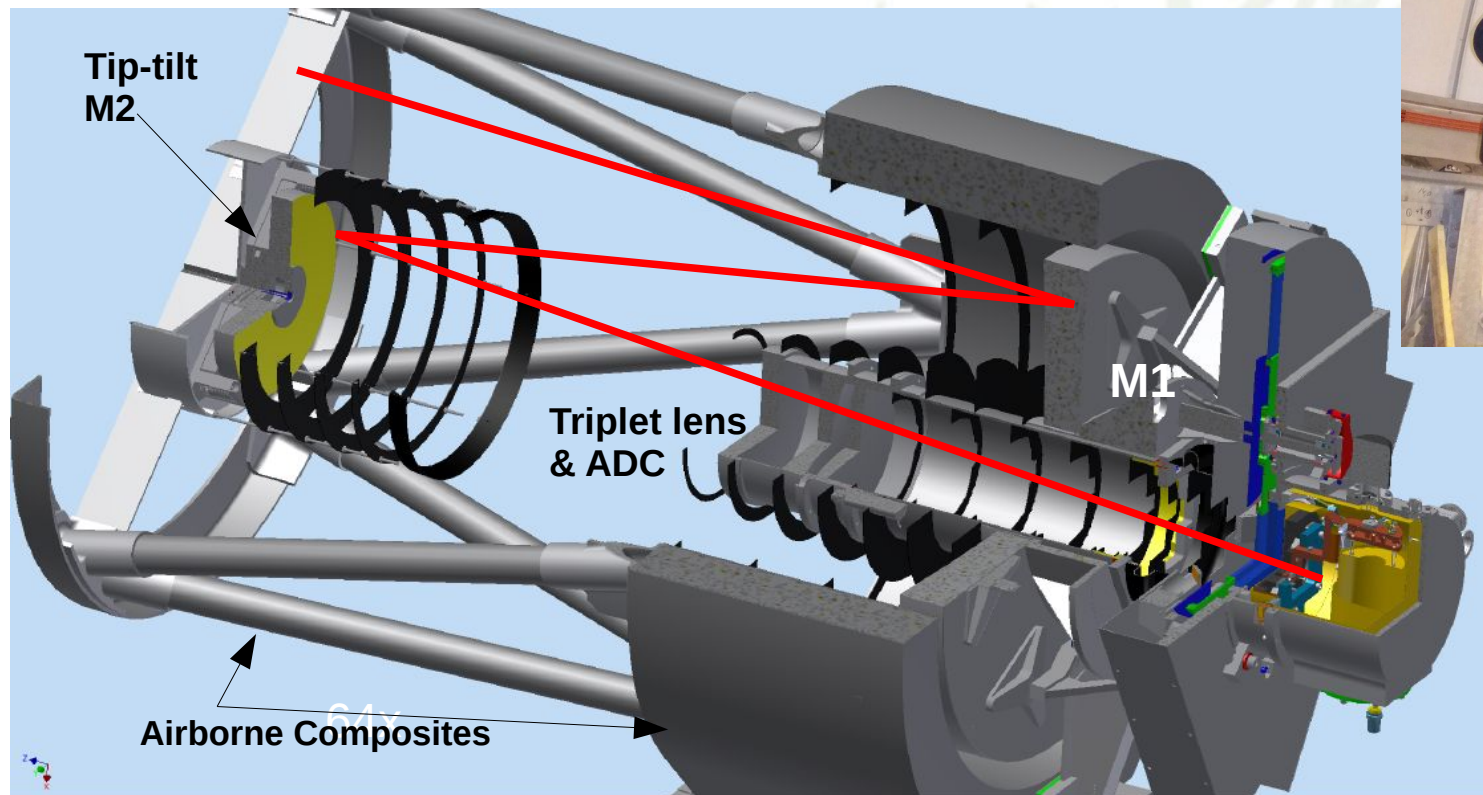

Design



CCD & Filters

- STA1600, 10.5k x 10.5k CCD, 9 μ pixel : 110 Mpixel chip
- Scale on sky: 0.564"/pix, total field of view: 2.7 sqd/telescope
- Readout time: 7 seconds (at 1 MHz on 16 ports), RON: 5.5 e-

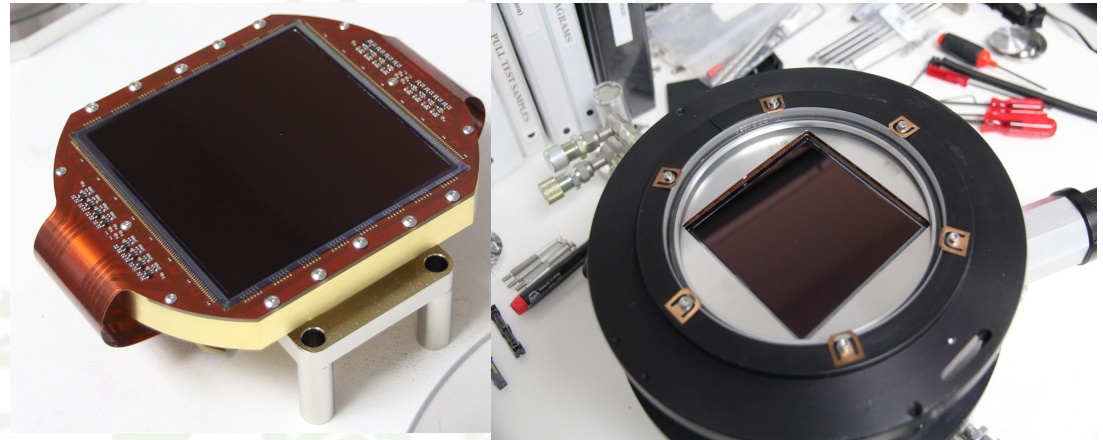
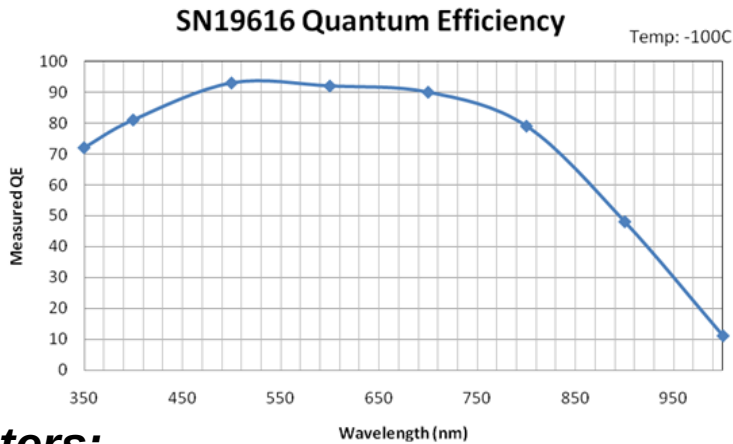

Filters: Sloan u,g,r,i,z filters plus broad-band q (440-720nm)

Astrodon BlackGEM set (BG-u,BG-g,BG-r,BG-i,BG-z and BG-vr (=q))

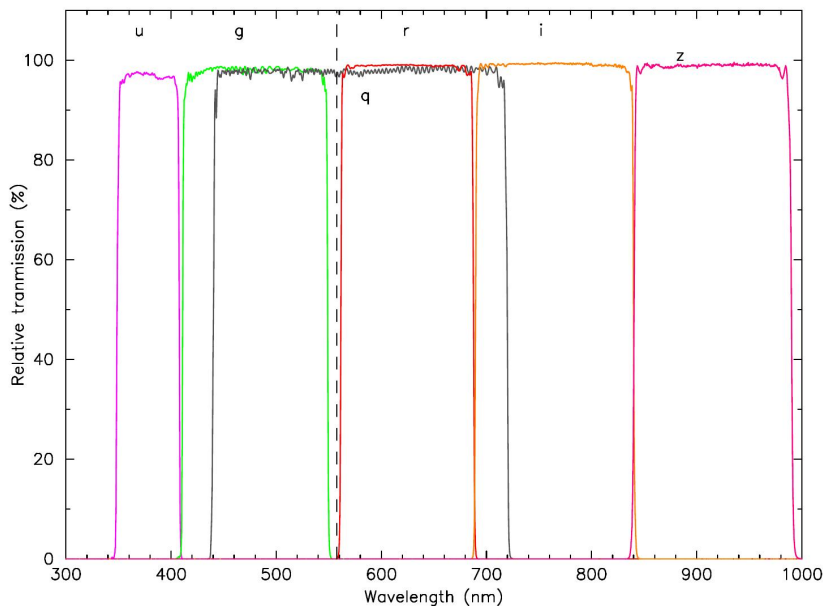

Astrodon BlackGEM set (BG-u,BG-g,BG-r,BG-i,BG-z and BG-vr (=q))

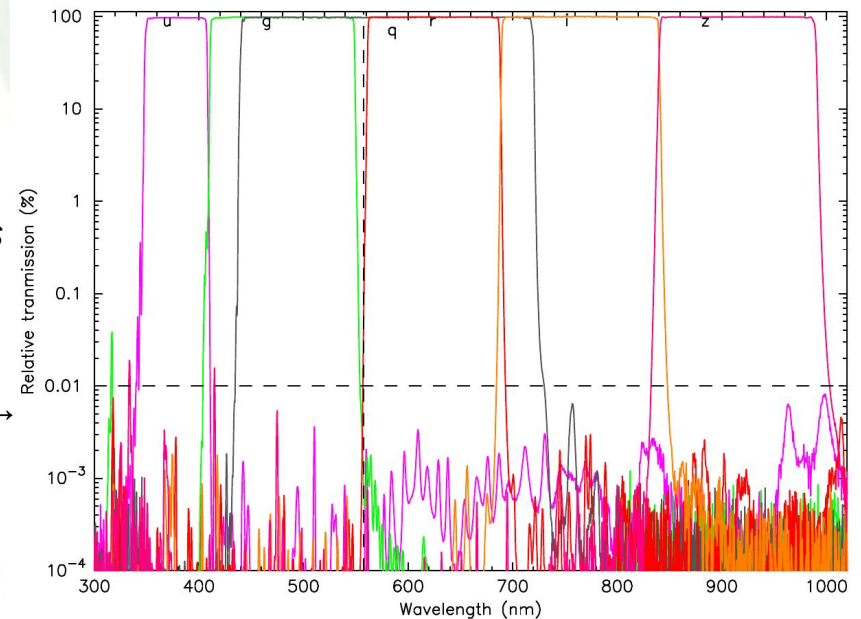

Measured curves

← Linear scale

Log scale →



Dome & Tower

5m Clamshell dome

7m high

Grid floor

Outer tube holds dome

Inner tube holds the telescope

Ventilation openings

TiO coating on outside to prevent daytime heating

Separate foundations

@ESO La Silla during installation

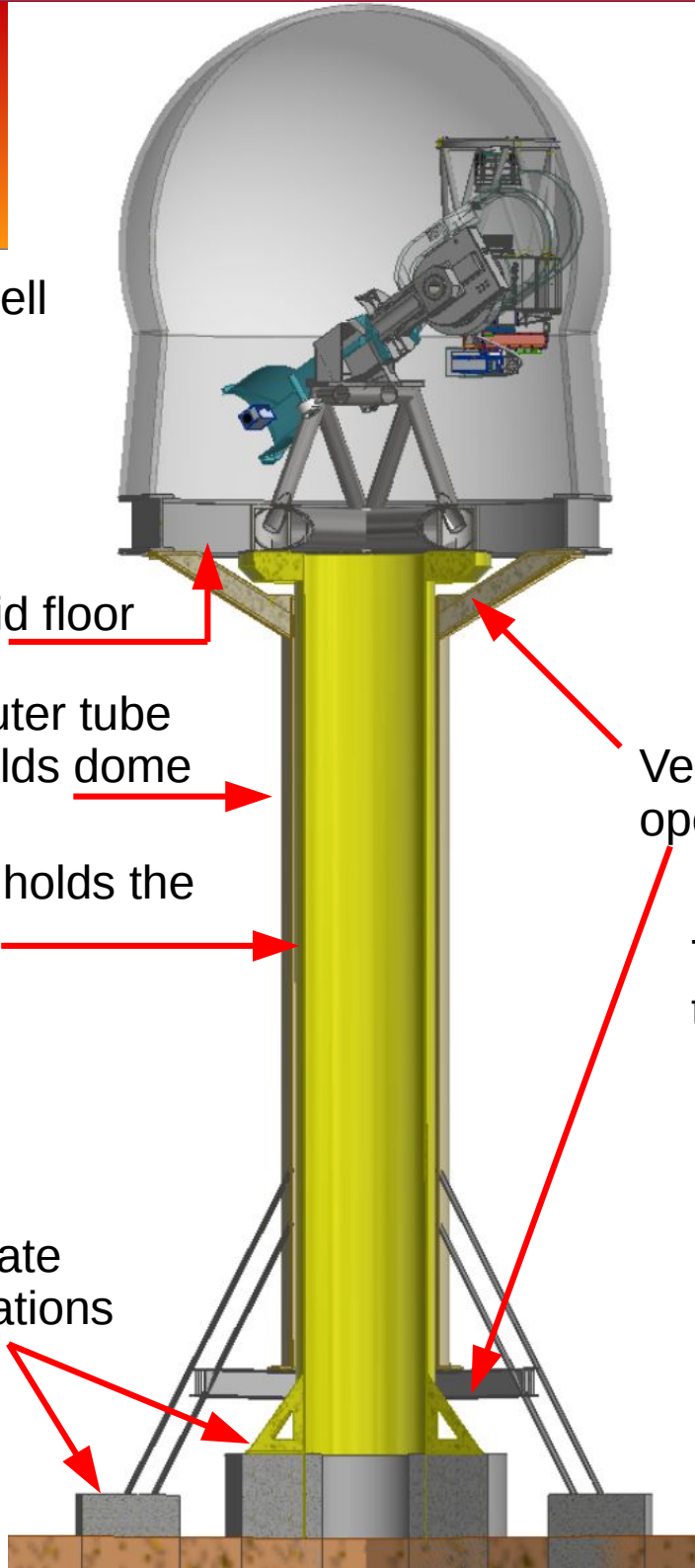



BlackGEM Surveys

- **BlackGEM Trigger Mode: 'Transients Galore'**
 - GW error box coverage in multiple colours
 - 100s of sqd in multiple times over ~week time scale down to $g=23$
(TDEs, SN of all types, Dwarf Novae, SN .Ia, SN Iax, etc.)
- **BlackGEM Southern Sky Survey: 'Southern Sloan'**
 - 30 000 sqd down to 22nd mag in u, g, q, r, i, z at 1" median seeing
 - By itself a fantastic resource for all kinds of science:
(galactic streams/structure, dwarf galaxies, stellar populations, 'gems', quasars, weak lensing, high-z galaxies, etc.)
- **BlackGEM Fast Synoptic Survey: 'Kepler on steroids'**
 - High cadence (1 min), multi-colour (u, q, i : simultaneous), wide-field
 - Kepler Short Cadence-type sampling on millions of objects
 - Deep drilling fields: thousands of exposures over weeks time-scale
 - Flexibility for experiments: continuous read-out, six filters, etc.
(fast transients, asteroids, KBOs, early SN, interacting binaries, eclipses etc.)
- **BlackGEM Local Transients program: Fast and Early**
 - Survey galaxy clusters ($d < 100$ Mpc) for young/fast transients every three hours in u, q, i



BlackGEM Data Flow

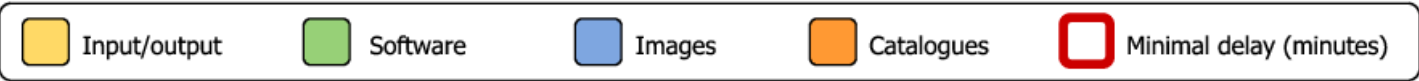
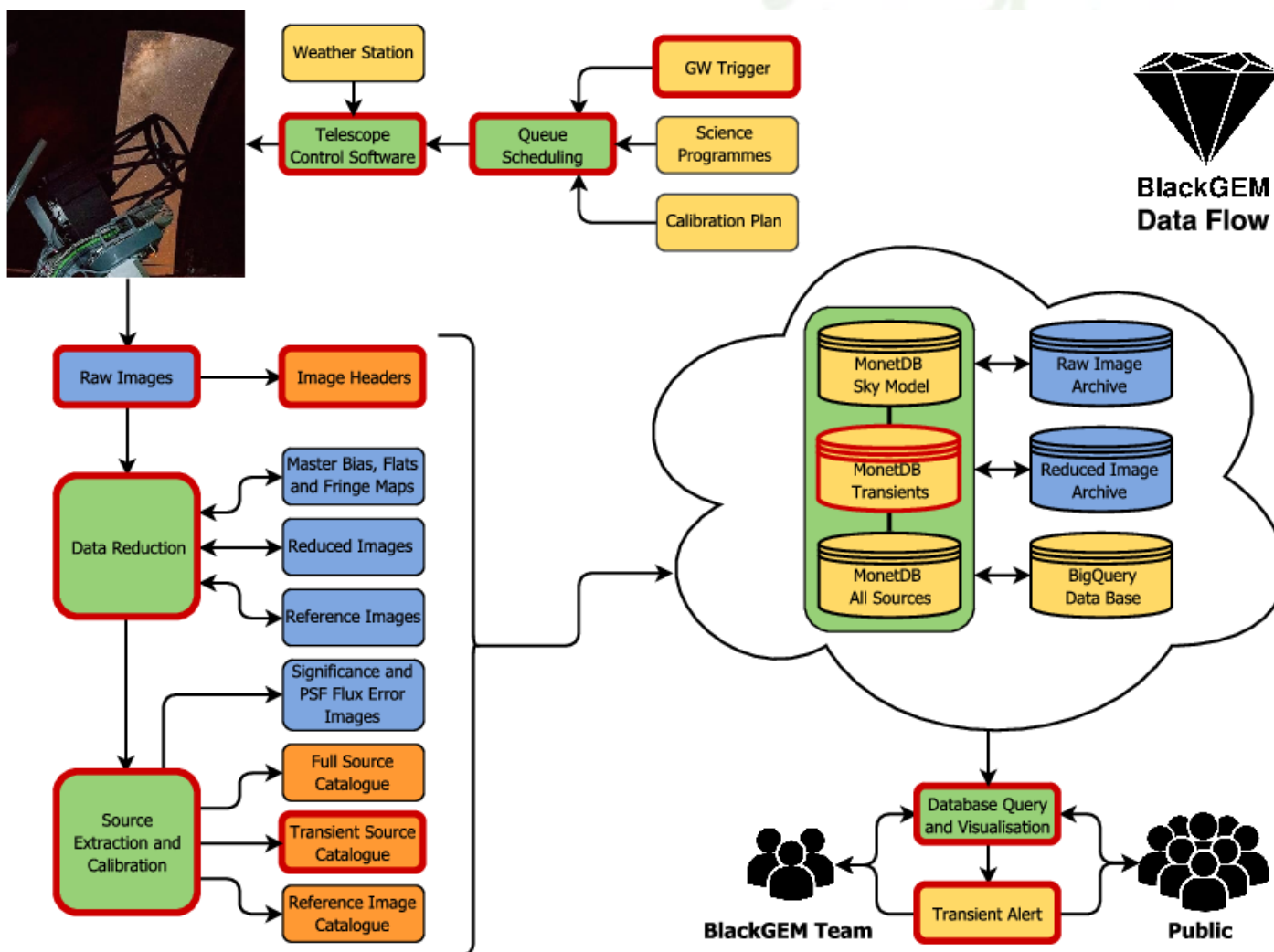



BlackCloud: A cloud solution



- Data flow pipeline based on *subpipe* data reduction flow SkyMapper
- Aim is to make all BlackGEM data instantly accessible:
 - A live database of any transient is maintained 'on the fly', live processing of 'previous' image during the night, instant alerts (T+5min)
 - All images kept on (spinning) disk for re-reductions and target photometry at any time
 - A live database of all sources, including variability.
- Complete set-up ideal for **cloud solution** on compute, database, storage
BlackGEM data: the **BlackCloud**.
- 1.8 Pb of data storage, 150 Tbyte of live database
(3 telescopes)





MeerLICHT Prototype

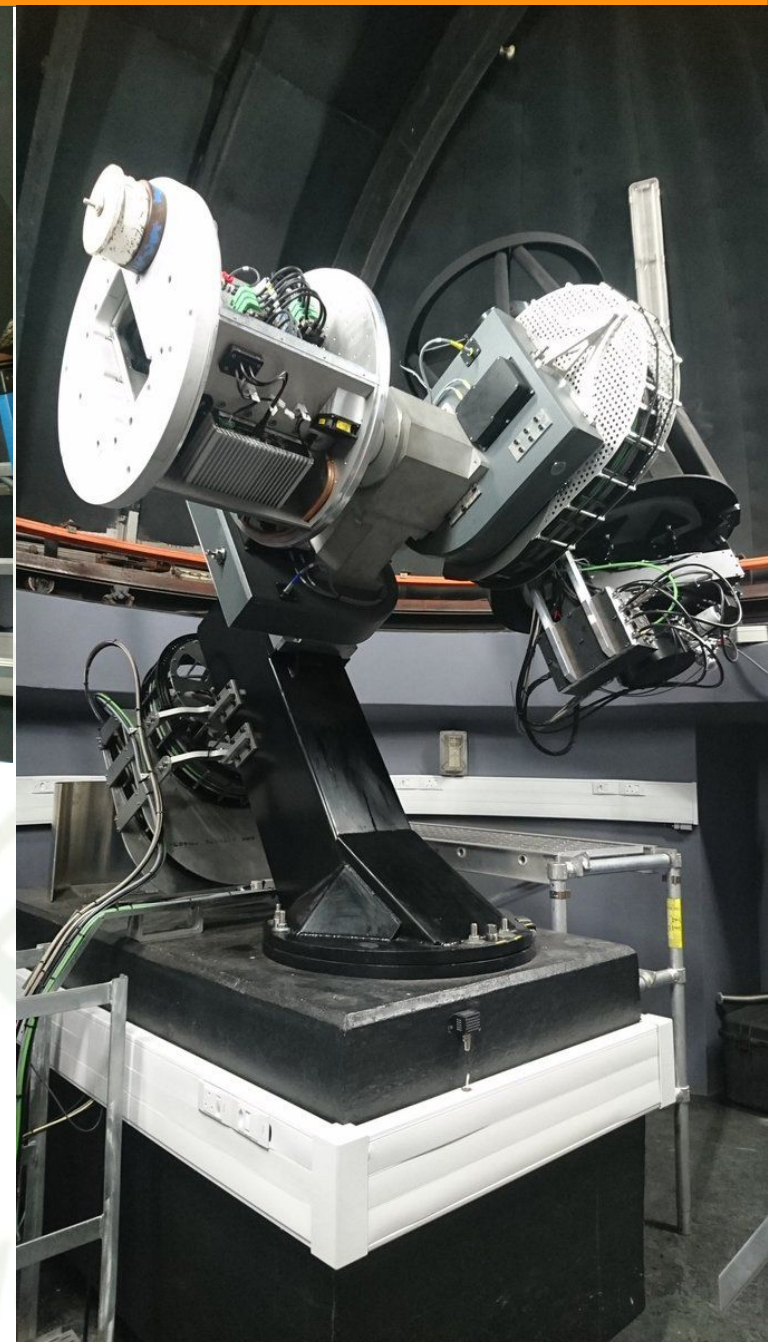

Operational at SAAO Sutherland

See [@MeerLICHT_ZA](https://twitter.com/MeerLICHT_ZA) on Twitter and www.meerlicht.org for more pictures

RADBOUD UN



Guide cameras & Filters

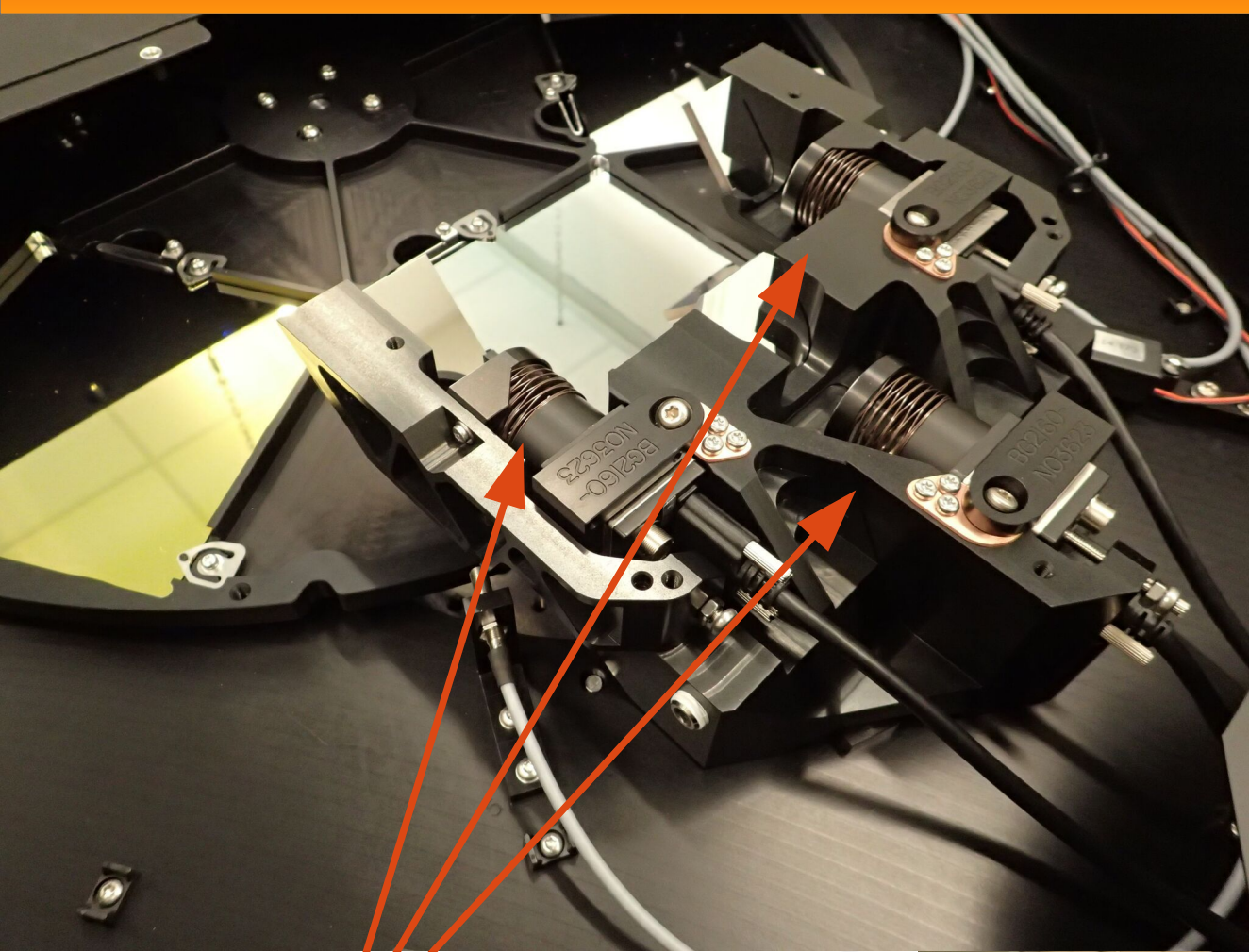

3 Guide cameras

Filter wheel

**Fornax
Cluster**

**Single
Pointing**

**60s int.
in 6 filters**

NGC1365



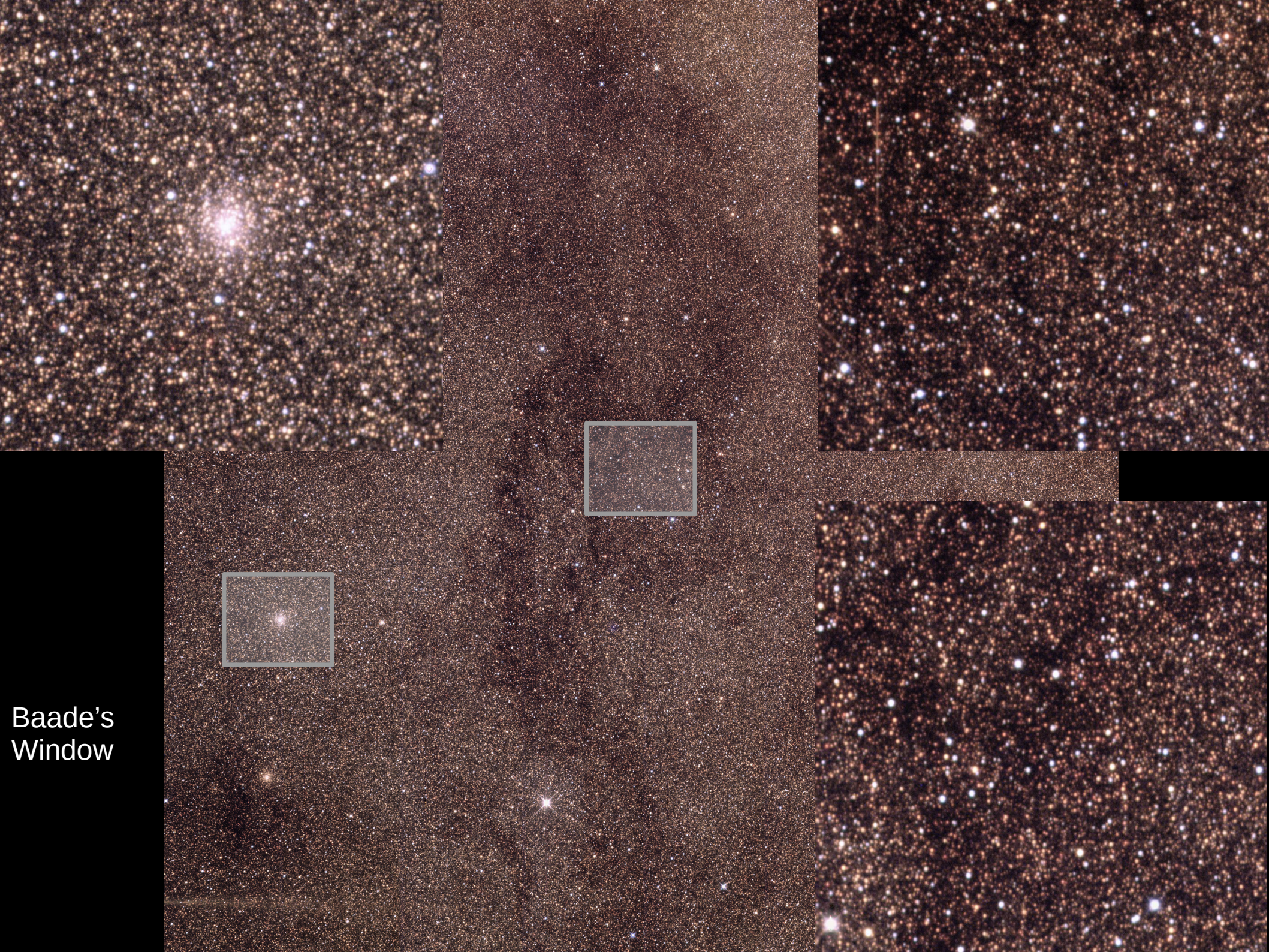

Baade's
Window



Science Verification



- Instantaneous Photometric calibration using SDSS/PanStarrs/SkyMapper

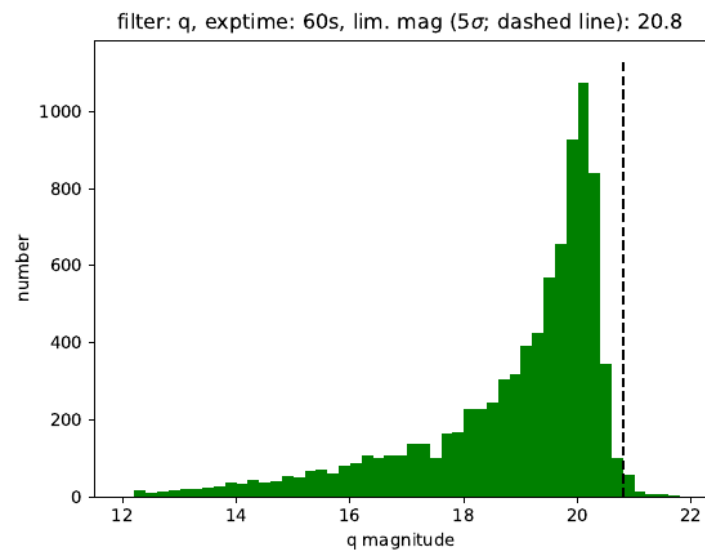
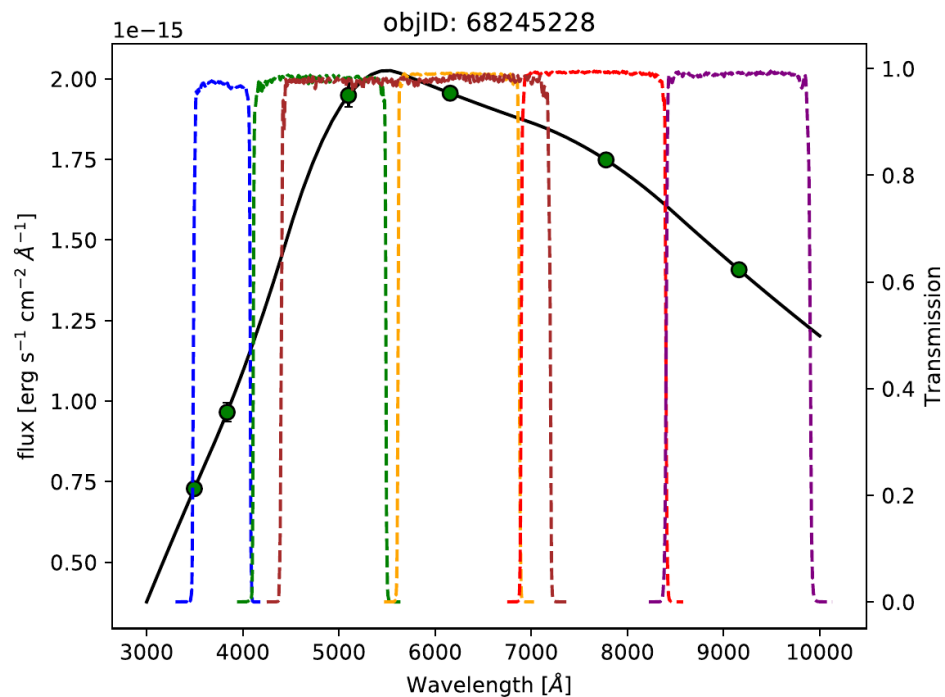

mean (black line): 23.956, std: 0.014, median (blue line): 23.955

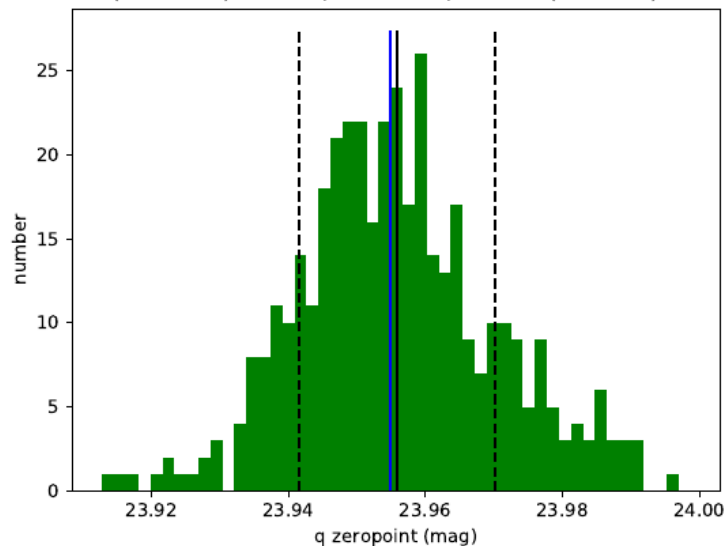

Zeropoint (1 e/s) MeerLICHT
Detected q-band 23.95

Expected for BlackGEM:
Zero-point q-band 24.2
(better coatings, better seeing)



BlackGEM Status (Feb20)



- All three telescopes are installed at ESO La Silla
- First two telescopes have seen first light on sky, showing excellent image quality and throughput.
- Commissioning will continue to ~April 2020 after which science operations will start.



First two telescopes installed (Oct 2019)



Third telescope being installed (Jan 2020)



BlackGEM Phase-2

- Expansion of BlackGEM to 15 telescopes (requires additional 15 MEuro)
- On current site at ESO La Silla; site prepared for taking 15 telescopes





BlackGEM Phase-2; Science

Science enabled by Phase 2 expansion

- **Multi-colour** GW follow-up, covering 100sqd per 2 hours in 3-5 filters, getting instantaneous colours
- **1 minute cadence** on deep-drilling fields in three filters (u,q,i)
- **Shadowing** of space missions (e.g. eROSITA, JWST or Gaia)
- Multi-colour (u,q,i) **hourly** observations of Local Universe
- (d<100 Mpc) galaxies

**Planned expansion for 2020-2022 time frame,
for 5-year operations**